

OPERATION AND INSTALLATION

Central ventilation appliance with heat recovery

- » LWZ 180
- » LWZ 280
- » LWZ 180 Enthalpie
- » LWZ 280 Enthalpie

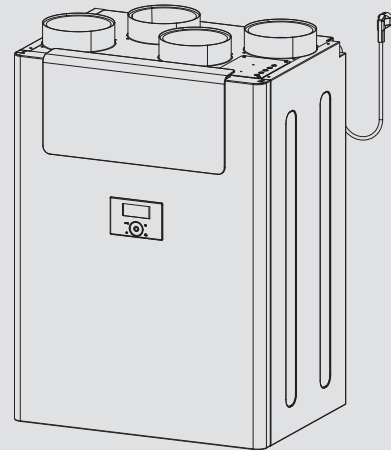

STIEBEL ELTRON

SPECIAL INFORMATION

OPERATION

| | |
|--|-----------|
| 1. General information | 29 |
| 1.1 Safety instructions | 29 |
| 1.2 Other symbols in this documentation | 29 |
| 1.3 Information on the appliance | 29 |
| 1.4 Standardised output data | 29 |
| 1.5 Units of measurement | 29 |
| 2. Safety | 29 |
| 2.1 Intended use | 29 |
| 2.2 General safety instructions | 30 |
| 2.3 Test symbols | 30 |
| 3. Appliance description | 30 |
| 3.1 Frost protection | 30 |
| 3.2 Bypass function | 30 |
| 4. Settings | 31 |
| 4.1 Switching the appliance on | 31 |
| 4.2 Programming unit | 31 |
| 4.3 Selecting the fan stage | 31 |
| 4.4 Activating time programs | 31 |
| 4.5 Menu | 32 |
| 4.6 Switching off the appliance | 34 |
| 5. Maintenance, cleaning and care | 34 |
| 5.1 Replacement filters | 34 |
| 5.2 Filter inspection and replacement | 34 |
| 6. Troubleshooting | 35 |

INSTALLATION

| | |
|---|-----------|
| 7. Safety | 36 |
| 7.1 General safety instructions | 36 |
| 7.2 Instructions, standards and regulations | 36 |
| 7.3 Operation of the appliance in buildings with combustion equipment | 36 |
| 7.4 Operating the appliance in passive houses | 37 |
| 8. Appliance description | 37 |
| 8.1 Standard delivery | 37 |
| 8.2 Accessories | 37 |
| 9. Preparation | 37 |
| 9.1 Storage | 37 |
| 9.2 Installation site | 37 |
| 9.3 Transport | 37 |
| 10. Installation | 38 |
| 10.1 Removing the front panel | 38 |
| 10.2 Mounting the appliance | 38 |
| 10.3 Connecting the condensate drain hose | 38 |
| 10.4 Air ducts | 39 |
| 10.5 Fitting the front panel | 40 |
| 10.6 Electrical connection | 40 |
| 11. Commissioning | 41 |
| 11.1 Initial start-up | 41 |
| 11.2 Recommissioning | 41 |
| 12. Settings | 42 |
| 12.1 Parameter | 42 |
| 12.2 Actual values | 44 |

| | |
|---------------------------------|-----------|
| 12.3 Code | 44 |
| 13. Appliance shutdown | 44 |
| 14. Maintenance | 44 |
| 15. Troubleshooting | 46 |
| 16. Disposal | 47 |
| 17. Specification | 48 |
| 17.1 Dimensions and connections | 48 |
| 17.2 Wiring diagram | 48 |
| 17.3 Fan diagram | 50 |
| 17.4 Data table | 51 |

GUARANTEE

ENVIRONMENT AND RECYCLING

SPECIAL INFORMATION

- The appliance may be used by children over 8 years of age and persons with reduced physical, sensory or mental capabilities or a lack of experience and expertise, provided that they are supervised or they have been instructed on how to use the appliance safely and have understood the potential risks. Children must never play with the appliance. Children must never clean the appliance or perform user maintenance unless they are supervised.
- The power cable must only be replaced (for example if damaged) by a qualified contractor authorised by the manufacturer, using an original spare part.
- Fix the appliance in position as described in chapter "Installation / Preparations".

OPERATION

1. General information

The chapters "Special information" and "Operation" are intended for both users and qualified contractors. The chapter "Installation" is intended for qualified contractors.



Note
Read these instructions carefully before using the appliance and retain them for future reference. Pass on the instructions to a new user if required.

1.1 Safety instructions

1.1.1 Structure of safety instructions



KEYWORD Type of risk
Here, possible consequences are listed that may result from failure to observe the safety instructions.
► Steps to prevent the risk are listed.

1.1.2 Symbols, type of risk

| Symbol | Type of risk |
|--------|-------------------------|
| | Injury |
| | Electrocution |
| | Burns (burns, scalding) |

1.1.3 Keywords

| KEYWORD | Meaning |
|---------|--|
| DANGER | Failure to observe this information will result in serious injury or death. |
| WARNING | Failure to observe this information may result in serious injury or death. |
| CAUTION | Failure to observe this information may result in non-serious or minor injury. |

1.2 Other symbols in this documentation



Note
General information is identified by the adjacent symbol.
► Read these texts carefully.

| Symbol | Meaning |
|--------|--|
| | Material losses (appliance damage, consequential losses and environmental pollution) |
| | Appliance disposal |

► This symbol indicates that you have to do something. The action you need to take is described step by step.

1.3 Information on the appliance

Connections

| Symbol | Meaning |
|--------|-------------|
| | Outdoor air |
| | Exhaust air |
| | Extract air |
| | Supply air |

1.4 Standardised output data

Information on determining and interpreting the specified standardised output data

Standard: EN 13141-7

The output data specifically mentioned in text, diagrams and technical datasheets has been determined in line with the test conditions described in the standard shown in the heading of this chapter.

Generally, these standardised test conditions will not fully meet the conditions found at the installation site of the system user. Depending on the chosen test method and the extent to which the selected method deviates from the conditions described in the standard shown in the heading of this chapter, any deviations can have a considerable impact. Additional factors that have an influence on the test values are the measuring equipment, the system configuration, the age of the system and the flow rates.

A confirmation of the specified output data can only be obtained if the conditions applicable to the relevant test match those of the standard shown in the heading of this chapter.

1.5 Units of measurement



Note
All measurements are given in mm unless stated otherwise.

2. Safety

2.1 Intended use

The appliance is designed as a mechanical ventilation unit with central supply and extract air routing.

The appliance is intended for domestic use. It can be used safely by untrained persons.

Appliance description

The appliance can also be used in non-domestic environments, e.g. in small businesses, as long as it is used in the same way. Any other use beyond that described shall be deemed inappropriate. Observation of these instructions and of the instructions for any accessories used is also part of the correct use of this appliance.

It is deemed inappropriate to:

- Use extract air containing grease, explosive gases, dust or adhesive aerosols
- Connect cooker hoods or vented tumble dryers to the ventilation system

Never adjust the settings of supply and extract air vents inside the rooms. These have been set up by a qualified contractor during commissioning.

2.2 General safety instructions



WARNING Injury

The appliance may be used by children over 8 years of age and persons with reduced physical, sensory or mental capabilities or a lack of experience and expertise, provided that they are supervised or they have been instructed on how to use the appliance safely and have understood the potential risks. Children must never play with the appliance. Children must never clean the appliance or perform user maintenance unless they are supervised.



WARNING Injury

The discharged cold air can cause condensation to be formed in the vicinity of the air discharge.

- ▶ Ensure that no risk of slipping due to wet conditions or ice formation occurs on adjacent footpaths and driveways at low temperatures.

2.3 Test symbols

See type plate on the appliance.

3. Appliance description

The appliance draws in outdoor air with a fan. A second fan extracts stale air from the rooms containing odours or moisture, e.g. kitchen, bathroom, WC. Extract air and outdoor air are routed through separate air ducts. Extract air and outdoor air are filtered by separate filters.

The extract air and outdoor air flow through a cross-counter-current heat exchanger. The outdoor air absorbs heat taken from the extract air. This enables a large proportion of thermal energy to be recovered.

The air flow rate is preset for each fan stage by the qualified contractor during commissioning. Constant flow rate control ensures that the air flow rates through the supply air and extract air fans are achieved irrespective of the duct pressure.

| | Stage | Display | |
|-------------------------------------|-------|----------------------------|---|
| Ventilation for humidity protection | 0 | "Power" symbol and digit 0 | Necessary ventilation for ensuring that the building structure is protected under normal conditions of use with somewhat reduced moisture loads, e.g. during temporary absence of users and no drying of washing in the residential unit. |
| Reduced ventilation | 1 | "Fan" symbol and digit 1 | Reduced ventilation is the ventilation necessary to meet hygiene standards and ensure protection of the building structure (moisture level) under standard conditions of use with partially reduced moisture and pollutant loads, e.g. as a result of intermittent user absence. |
| Standard ventilation | 2 | "Fan" symbol and digit 2 | Standard ventilation is the ventilation necessary to meet hygiene standards and ensure protection of the building structure when users are present. |
| Intensive ventilation | 3 | "Fan" symbol and digit 3 | Intensive ventilation is increased ventilation with a higher flow rate to reduce load peaks, e.g. for rapid ventilation during or after a party. You can switch on intensive ventilation with the "intensive ventilation" button or with an optionally connectible external pushbutton. |

LWZ 180 Enthalpie, LWZ 280 Enthalpie: Enthalpy heat exchanger

The enthalpy heat exchanger is a highly efficient, moisture-transferring counter-current heat exchanger with a selective membrane. The membrane helps to recover moisture from the extract air and transfer it to the supply air. This prevents the relative humidity in the rooms from dropping too low during the winter months.

3.1 Frost protection

The appliance has a frost protection controller, which ensures that it works to optimum effect even at low outside temperatures. If the outdoor air temperature falls below the selected frost protection value, the electric preheating coil is switched on. This prevents the cross-counter-current heat exchanger from freezing up. When the preheating coil is active, the "frost protection" symbol illuminates on the display.

3.2 Bypass function

The appliance has an integral bypass damper. The bypass damper enables the supply of fresh air which does not flow through the heat exchanger. You can specify the operating mode of the bypass damper with one parameter on the programming unit (see chapter "Settings / Parameters").

Utilising cool outdoor air

Cool, fresh air is required on summer nights in particular. In such cases, in automatic mode, as much of the warm air in the home as possible is displaced by cooler fresh air.

Utilising warm outdoor air

In spring and autumn, the appliance can increase the room temperature by opening the bypass damper in automatic mode and drawing warmer outdoor air into the building.

4. Settings

4.1 Switching the appliance on

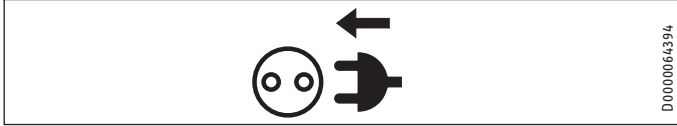

► Plug the appliance into a standard socket.

4.2 Programming unit

Up to four programming units can be connected to the ventilation unit.

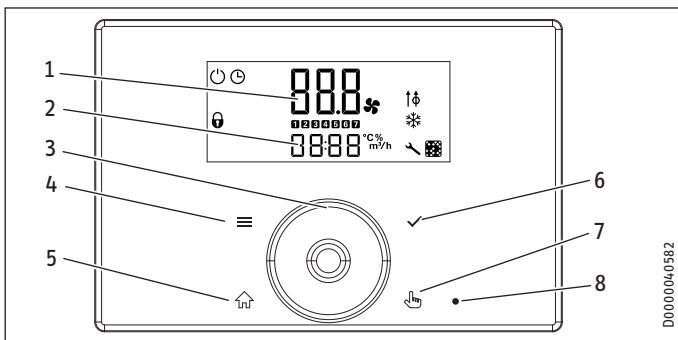

- 1 Upper display: Fan stage, parameter number or number of an actual value
- 2 Lower display: Values (e.g. temperature or air flow rate)
- 3 Touch-Wheel
- 4 "MENU" button
- 5 "HOME" button
- 6 "OK" button
- 7 "Intensive ventilation" button
- 8 "Intensive ventilation" indicator

4.2.1 Controls

| Controls | Description |
|--------------------------------|---|
| "MENU" button | Press this button for approx. one second to call up the menu from the standard display. Within the menu, press this button to return to the beginning of the menu. Parameter P1 is displayed. When setting a parameter value, press this button to exit setting of the parameter. Any changes made will not be saved. |
| "OK" button | In order to set the parameter, you must first make it editable by pressing the "OK" button. Then you can change the value with the Touch-Wheel. Once you have set the parameter, confirm your entry with the "OK" button. |
| "HOME" button | Calls up the standard display |
| "Intensive ventilation" button | Use this button to switch the appliance to intensive ventilation. You can set the runtime for intensive ventilation in parameter P2. Once this runtime has expired, the appliance returns to the previously applicable fan stage. |
| Touch-Wheel | From the home screen, you can use the Touch-Wheel to select fan stages 0, 1 and 2, and activate the time programs. The "time" symbol indicates that time programs are activated. Use the Touch-Wheel to select a parameter or value in the menu. If you turn the Touch-Wheel quickly, the increment size changes after a while. |

Press the "HOME" and "OK" buttons simultaneously to activate the function block. The "padlock" symbol appears. Then you can wipe the programming unit clean without inadvertently changing any settings. Press the "HOME" and "OK" buttons simultaneously for two seconds to deactivate the function block.

4.2.2 Display

If no user action occurs within the time selected in the illumination duration parameter, the display backlighting switches off and the standard display appears.

Press any button to switch the background lighting on again.

| Symbol | Description |
|--------|--|
| | Power: This symbol indicates that the appliance is switched on and the fans are operating in "humidity protection" mode. |
| | Time: This symbol indicates that the appliance is operating in time program mode. Depending on the program, the appliance is operated at different fan stages. |
| | Fan: This symbol, with the associated digit, indicates the fan stage at which the appliance is currently running. |
| | Bypass active: This symbol indicates that the air flow is bypassing the heat exchanger. No heat is recovered. |
| | This symbol is displayed when the function block is activated. Press the "HOME" and "OK" buttons simultaneously for two seconds to deactivate the function block. |
| | Filters: Change the filter when this symbol appears. |
| | Frost protection: This symbol is displayed when the appliance has turned on the preheating coil for frost protection. |
| | Service/fault: The "service/fault" symbol illuminates permanently in the event of faults that do not impair the basic function of the appliance. The "service/fault" symbol flashes if a serious fault has occurred. Call your qualified contractor. |

4.3 Selecting the fan stage

From the home screen, you can use the Touch-Wheel to select fan stages 0, 1 and 2. The set value is accepted without you having to press a button to confirm it.

You cannot activate intensive ventilation with the Touch-Wheel. To switch on intensive ventilation, press the "intensive ventilation" button for approx. one second. When intensive ventilation is activated, the "intensive ventilation" indicator illuminates.

You can activate intensive ventilation with an external pushbutton or with the "intensive ventilation" button. You can only deactivate intensive ventilation with the "intensive ventilation" button.

4.4 Activating time programs

The "time" symbol indicates that time programs are activated.

If the time programs are not activated, turn the Touch-Wheel clockwise to switch from the home screen. After fan stage 2, the fan stage set in the time program appears along with the "time" symbol.



Note

If you switch the appliance to time program operation, time programs must be entered in the "prog" menu. Otherwise the appliance continues to run without a time limit in set fan stage 2.

Enter the time program settings in the menu.

OPERATION

Settings

At times where there is no time program defined, the appliance runs in set fan stage 2.

4.5 Menu

| Display | Description |
|------------|--|
| ■ P1 - Pxx | Parameter |
| ■ I1 - Ixx | Actual values |
| ■ Pro | Programs |
| ■ Cod | Entry of the code for unlocking protected parameters and actual values |

► To access the parameters, press the "MENU" button.

The "HOME" button takes you to the standard display. If you have not changed any settings for a while, the appliance automatically switches back to the standard display.

4.5.1 Parameter

| | Description | Options | Unit | Min. | Max. | Standard |
|-----|--|--|------|-------|-------|----------|
| P1 | Set room temperature | | °C | 5 | 28 | 20 |
| P2 | This parameter defines the runtime for intensive ventilation. After this time has expired, the appliance returns to the previously applicable fan stage. | | Min. | 1 | 240 | 30 |
| P3 | Bypass mode | 0 1 2 3 | | | | 2 |
| P4 | Reset filter | 1 0 | | | | |
| P28 | Enable fan | On OFF | | | | On |
| P80 | Day | | | 1 | 7 | |
| P81 | Time | | | 00:00 | 23:59 | |
| P82 | Level of lighting | | | 2 | 10 | 10 |
| P83 | Mode of backlighting | Auto On OFF | | | | Auto |
| P84 | Illumination duration | | s | 10 | 500 | 60 |
| P85 | Lower standard display | OFF Time Set room temperature Extract air temp. Extract air humidity | | | | OFF |

In order to set the parameter, you must first make it editable by pressing the "OK" button. Then you can change the value with the Touch-Wheel. If you do not press the "OK" button to make the parameter editable, activating the Touch-Wheel causes the next parameter to be displayed.

Press the "OK" button to save the set value for a parameter. If you do not confirm the parameter change with the "OK" button, your change will be lost.

■ P1: Set room temperature

Use this parameter to set the outside temperature from which the bypass damper ensures that outdoor air bypasses the heat exchanger and flows directly into the building.

■ P3: Bypass mode

| | Effect |
|---|---|
| 0 | The bypass is permanently disabled. Air flows through the heat exchanger. |
| 1 | The bypass is active. The air flow bypasses the heat exchanger. |
| 2 | The bypass operates with summer day detection. This option is set in the delivered condition. |
| 3 | The bypass operates subject to the extract air temperature. |



Note

The qualified contractor can set the parameters mentioned in the description of this parameter.

P24: Bypass enable temperature

P25: Bypass blocking temperature

P26: Bypass hysteresis

P27: Temperature differential for enabling the bypass

P3 = 2: Bypass with summer day detection

In order for the bypass to be enabled, the following must apply for 2 hours: Outdoor air temperature > Set room temperature + P27

If all the following conditions are met, the appliance switches to bypass mode.

- Outdoor air temperature < Extract air temp. - P26
- Extract air temp. > Set room temperature

If one of the following conditions is met, the appliance terminates bypass mode.

- Outdoor air temperature < P25
- Outdoor air temperature > Extract air temp. - P26
- Extract air temp. < Set room temperature

P3 = 3: Bypass subject to extract air temperature

In order for the bypass to be enabled, the following must apply for 2 hours: Extract air temp. > Set room temperature + P27

This delayed enabling prevents cooling down in spring and autumn.

If all the following conditions are met, the appliance switches to bypass mode.

- Outdoor air temperature < Extract air temp. - P26
- Extract air temp. > Set room temperature

If one of the following conditions is met, the appliance terminates bypass mode.

- Outdoor air temperature < P25
- Outdoor air temperature > Extract air temp. - P26
- Extract air temp. < Set room temperature

■ P4: Reset filter

► Set this parameter to 1 after changing the filters. The appliance resets the filter runtime to 0. This parameter is automatically reset to 0.

OPERATION

Settings

■ P28: Enable fan

You can switch off the fans at any time via the programming unit menu, e.g. to deactivate ventilation if there is a fire.

| | Effect |
|-----|--|
| OFF | The fans are deactivated. "OFF" and the fan icon flash on the display. |
| On | The fans are enabled. |

■ P80: Day

| | |
|---|-----------|
| 1 | Monday |
| 2 | Tuesday |
| 3 | Wednesday |
| 4 | Thursday |
| 5 | Friday |
| 6 | Saturday |
| 7 | Sunday |

■ P83: Mode of backlighting

| | Effect |
|------|---|
| On | Backlighting switched on |
| OFF | Backlighting switched off |
| Auto | If no user action occurs within the time selected in the illumination duration parameter, the display backlighting switches off and the standard display appears. |

■ P84: Illumination duration

If no user action occurs within the time selected in the illumination duration parameter, the display backlighting switches off and the standard display appears.

■ P85: Lower standard display

Use this parameter to define what is displayed in the lower section of the standard display. If the appliance detects a fault, the fault is indicated in the lower section of the standard display.

4.5.2 Actual values

| Display | Description | Unit |
|----------|-----------------------------------|------|
| ■ I1 | Bypass damper status | |
| ■ I2 | Extract air temp. | °C |
| ■ I3 | Relative humidity of extract air | % |
| ■ I4 | Filter service life | h |
| ■ I5 | Appliance software version | |
| ■ I6 | Unit software patch | |
| ■ I7 | Terminal device serial number | |
| ■ I8 | Programming unit software version | |
| ■ I70-79 | Fault memory | |

Faults detected by the appliance are stored in actual values I70 to I79. The latest fault is stored in I70; the oldest in I79. If no faults are entered, dashes are shown. The latest fault is also shown in the lower section of the standard display. Possible faults are listed for qualified contractors in the "Troubleshooting" chapter.

4.5.3 Programs

■ Pro

The appliance offers the option to set 21 time programs. Switch between the time programs using the Touch-Wheel. Press the "OK" button to switch to setting a time program.

| Time program x | x.1 Day or group of days | x.2 Fan stage | x.3 Start time | x.4 Stop time |
|----------------|-----------------------------|------------------|-------------------|------------------|
| □ ■ 1 | | | | |
| □ ■ 2 | | | | |
| □ ■ 3 | | | | |
| □ ■ 4 | | | | |
| □ ■ 5 | | | | |
| □ ■ 6 | | | | |
| □ ■ 7 | | | | |
| □ ■ 8 | | | | |
| □ ■ 9 | | | | |
| □ ■ 10 | | | | |
| □ ■ 11 | | | | |
| □ ■ 12 | | | | |
| □ ■ 13 | | | | |
| □ ■ 14 | | | | |
| □ ■ 15 | | | | |
| □ ■ 16 | | | | |
| □ ■ 17 | | | | |
| □ ■ 18 | | | | |
| □ ■ 19 | | | | |
| □ ■ 20 | | | | |
| □ ■ 21 | | | | |

Setting a time program begins with selecting a day of the week or a group of days. Press "OK". Set the day using the Touch-Wheel. Confirm with the "OK" button.

Use the Touch-Wheel to switch to setting the fan stage. Press "OK". Set the fan stage in which the appliance runs when the time program takes effect using the Touch-Wheel. Confirm with the "OK" button.



Note

You cannot switch on fan stage 3 with time programs.

Use the Touch-Wheel to switch to setting the start time. Press "OK". Set the start time of the respective time program using the Touch-Wheel. Confirm with the "OK" button.

Use the Touch-Wheel to switch to setting the stop time. Press "OK". Set the stop time of the respective time program using the Touch-Wheel. Confirm with the "OK" button. To delete a time program, go to the menu item where the day or group of days is selected for the respective time program. Turn the Touch-Wheel anti-clockwise until the day disappears and dashes appear in the lower section of the display.



Note

In the case of overlapping time programs, the program with the highest number takes priority.

OPERATION

Maintenance, cleaning and care



Note

At times where there is no time program defined, the appliance runs in set fan stage 2.

Example

| | Time scale | Stage |
|------------------|---------------|-------|
| Monday - Friday | 06:00 - 22:00 | 2 |
| | 22:00 - 06:00 | 1 |
| Saturday, Sunday | 07:00 - 23:00 | 2 |
| | 23:00 - 07:00 | 1 |

| x | x.1 Day or group of days | x.2 Fan stage | x.3 Start time | x.4 Stop time |
|------|-----------------------------|------------------|-------------------|------------------|
| ☐■ 1 | 1/2/3/4/5 | 1 | 22:00 | 00:00 |
| ☐■ 2 | 1/2/3/4/5 | 1 | 00:00 | 06:00 |
| ☐■ 3 | 6/7 | 1 | 23:00 | 00:00 |
| ☐■ 4 | 6/7 | 1 | 00:00 | 07:00 |

4.5.4 Code

■ Cod

You can use this menu item to enable actual values and parameters, which are reserved for qualified contractors.

| Effect |
|---|
| A0 The only parameters displayed are those that have been released for the appliance user and can therefore be accessed without a code. |
| A1 Parameters for qualified contractors |
| A2 Parameters for service department |

A1 or A2 is shown on the display when you enter the correct four-digit code.

If you switch to the actual values or parameters, you see the enabled parameters.



Note

After entering the code, switch to the menu by pressing the "MENU" button. If you first switch to the standard display by pressing the "HOME" button, the parameter block is reactivated.

4.6 Switching off the appliance

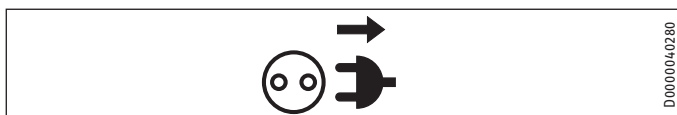

The appliance has no ON/OFF switch. Disconnect the power supply by pulling the power plug from its socket.

5. Maintenance, cleaning and care

Maintenance by the user is limited to filter inspection and replacement required at certain intervals.

5.1 Replacement filters

| Product name | Part number | Description | |
|---------------|-------------|----------------------------|-------------------------------|
| FMS G4-10 180 | 234147 | Coarse particle filter mat | ISO Coarse > 60 % (G4) |
| FMK M5-2 180 | 234148 | Fine filter | ePM ₁₀ ≥ 50 % (M5) |
| FMK F7-2 180 | 234208 | Fine filter | ePM ₁ ≥ 50% (F7) |

5.2 Filter inspection and replacement



Material losses

Never operate the appliance without filters.

► Inspect the filters for the first time three months after commissioning the appliance.

The qualified contractor can lengthen or shorten the interval for inspecting filters depending on the level of contamination.

The "filter" symbol appears after a time set by the qualified contractor.

If the "filter" symbol illuminates, check the filters. Change the filters if the surface is covered completely in dirt or the filter is discoloured throughout.

Change the filters at least every 12 months.

Filter inspection

► Pull the mains plug out of the socket.

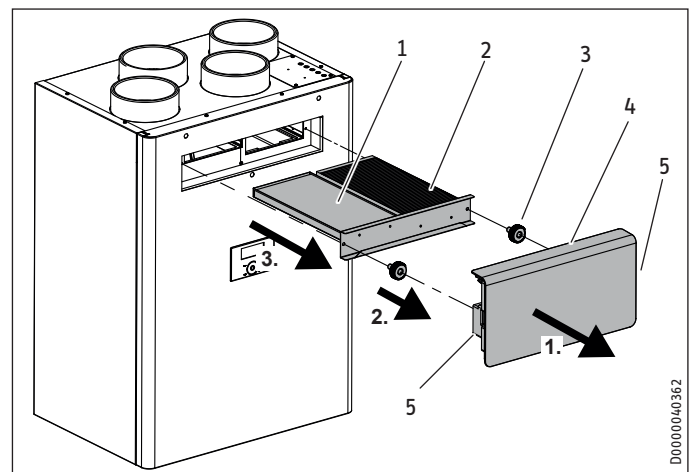

- 1 Extract air filter
- 2 Outdoor air filter
- 3 Knurled screw for securing the filter drawer
- 4 Fascia
- 5 Locking tabs

The fascia is fastened to the appliance with locking tabs.

- To disengage the locking tabs, press the grip areas on the fascia sides.
- Remove the fascia from the appliance.
- Undo the knurled screws securing the filter drawer.
- Pull the filter drawer forwards to remove it from the appliance.

- ▶ If necessary, place one or more new filters in the filter drawer. Ensure that the filters are installed in the intended position. Air flows through the filters from top to bottom. The flow direction is indicated with an arrow on the filter drawer fascia. The outdoor air filter is marked with an arrow. Install the outdoor air filter with the arrow pointing in the flow direction. The extract air filter is imprinted with the words "Clean air side", which must be at the bottom.



Material losses

Operate the appliance with at least the recommended filter class. Ensure that filters are fitted accurately so they can function properly.

- ▶ Push the filter drawer into the appliance.
- ▶ Secure the filter drawer with the knurled screws.
- ▶ Fit the fascia.
- ▶ Plug the mains plug into a standard socket.
- ▶ Carry out a filter reset by setting parameter P4 to 1. The "filter" symbol disappears. The appliance resets the filter runtime to 0.
- ▶ Make a note of the filter change date.



Note

There is a label for each filter on the front panel.

- ▶ Once you have performed a filter change, erase the previously entered dates in the "Last" and "Next" columns.
- ▶ Enter today's date in the "Last" column.
- ▶ Enter the date for the next filter change in the "Next" column. For the period between "Last" and "Next", use the value set by the qualified contractor in parameter P19.

- ▶ Order new filters in good time or purchase a filter subscription.



Note

If other filters are installed in the system, e.g. filters in the extract air vents or a filter box, also perform the inspection there and change the filter(s) if necessary.

6. Troubleshooting

Faults detected by the appliance are stored in actual values I70 to I79. The latest fault is also shown in the lower section of the standard display.

If you cannot remedy the fault, contact your qualified contractor. To facilitate and speed up your request, provide the number from the type plate (000000-0000-000000).

INSTALLATION

7. Safety

Only a qualified contractor should carry out installation, commissioning, maintenance and repair of the appliance.

7.1 General safety instructions

We guarantee trouble-free function and operational reliability only if original accessories and spare parts intended for the appliance are used.



WARNING Electrocutation

Do not reach into the interior of the appliance through the "Outdoor air" connection when the power supply is switched on.

7.2 Instructions, standards and regulations



Note

Observe all applicable national and regional regulations and instructions.



WARNING Injury

In connection with the fire prevention regulations concerning the installation of ventilation systems, observe all country-specific regulations and requirements. In Germany, these are particularly the building regulation guideline on fire prevention requirements of ventilation systems in its applicable version.

7.3 Operation of the appliance in buildings with combustion equipment

The term "combustion equipment" used below includes, for example, tiled stoves, fireplaces and equipment with gas combustion.



WARNING Injury

Ventilation units can generate negative pressure in the dwelling. If combustion equipment is operating at the same time, combustion exhaust gases can penetrate the room where the combustion equipment is installed. It is therefore important to observe a number of points for simultaneous operation of a ventilation unit and combustion equipment.

The engineering, installation and operation of the ventilation unit and combustion equipment must be carried out in accordance with national and regional regulations.

7.3.1 Planning safety measures

Together with the relevant authorities, engineers plan the safety measures that are required for simultaneous operation of a ventilation unit and combustion equipment.

Alternate operation

Alternate operation means that, when the combustion equipment is started, the mechanical ventilation system is switched off and/or cannot be started. Alternate operation must be ensured by appropriate measures, e.g. automatically enforced shutdown of the ventilation unit.

Simultaneous operation

For simultaneous operation of combustion equipment and a mechanical ventilation system, we recommend choosing approved room sealed combustion equipment (in Germany, with DIBt approval).

If open flue combustion equipment is operated in the dwelling at the same time as a ventilation unit, combustion exhaust gases must be prevented from penetrating the home as a result of possible negative pressure in the room.

The ventilation unit may only be operated in combination with intrinsically safe combustion equipment. This combustion equipment has, for example, a draught hood or an exhaust gas monitor and is permitted to be operated in conjunction with ventilation units. Alternatively, external, tested safety equipment can be connected to monitor the operation of the combustion equipment. For example, you can install differential pressure monitoring to monitor the chimney draught and to switch off the ventilation unit in the event of a fault.

The equipment for differential pressure monitoring must fulfil the following requirements:

- Monitoring of the differential pressure between the connection piece to the chimney and the room where the combustion equipment is installed
- Possibility of matching the shutdown value for the differential pressure to the minimum draught requirement for the combustion equipment
- Floating contact to switch off ventilation
- Optional connection of a temperature capturing device so that differential pressure monitoring is only enabled when the combustion equipment is in operation and so that unwanted shutdowns due to environmental influences can be avoided



Note

Differential pressure switches that use the pressure differential between the outdoor air pressure and the pressure in the room where the combustion equipment is sited as a response criterion are not suitable.



Note

We recommend installing and regularly maintaining a carbon monoxide detector in accordance with EN 50291 for operation of any combustion equipment.

7.3.2 Commissioning

When commissioning the ventilation unit, it is important to check and document in the commissioning log that combustion exhaust gases are not penetrating the dwelling in a quantity that is harmful to health.

Commissioning in Germany

Acceptance is carried out by the local flue gas inspector.

Commissioning outside Germany

Acceptance must be carried out by a specialist. In case of doubt, you must involve an independent expert in the acceptance procedure.

7.3.3 Maintenance

Regular maintenance of the combustion equipment is prescribed. Maintenance includes checking the exhaust gas extraction system, the free pipe cross-sections and the safety equipment. The relevant qualified contractor responsible must prove that there is a sufficient flow of combustion air.

7.4 Operating the appliance in passive houses

If operating the appliance in a passive house, the factory-fitted outdoor air filter must be replaced. See chapter "Appliance description / Accessories".

8. Appliance description

8.1 Standard delivery

The following are delivered with the appliance:

- Wall mounting bracket
- 2 star grips as spacers for the rear of the appliance
- Condensate drain hose, hose clip, mounting bend
- 4 twin connectors, nominal diameter 160

8.2 Accessories

- Programming unit
- For installation of the equipment in passive houses: Outdoor air filter ePM1 \geq 50% (F7)

You can obtain ventilation pipes, extract air and supply air vents and similar accessories from us.

LWZ 180, LWZ 280

- Enthalpy heat exchanger

9. Preparation

9.1 Storage



Material losses

Never store the appliance in dusty places.

9.2 Installation site



Material losses

Never install the appliance outdoors.



Material losses

Check whether the wall can bear the weight of the appliance. A plaster board or metal framed wall is inadequate. Additional measures such as a double skin or additional supports would be needed in such cases.

- Ensure the appliance is level after installation.
- The installation room must have an adequate condensate drain with siphon.
- The installation room must be free from the risk of frost.

Minimum clearances

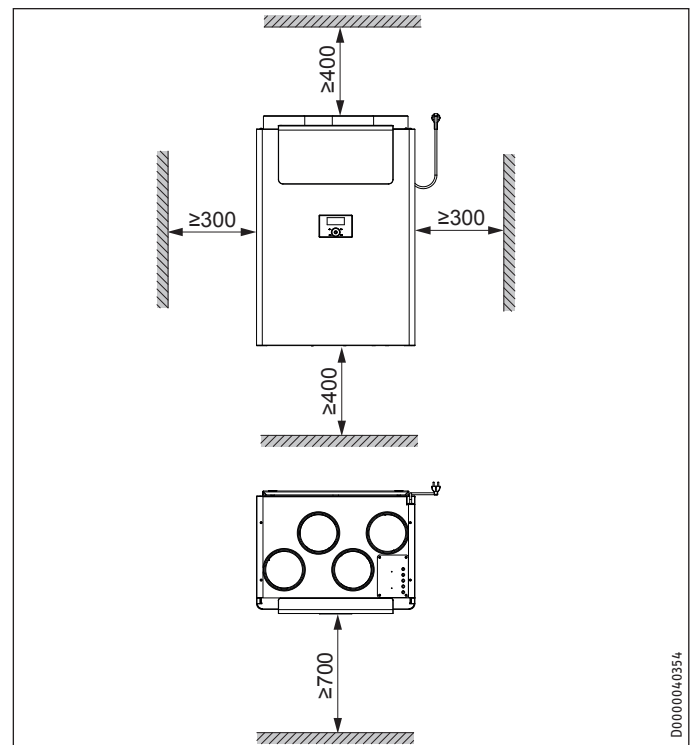

9.3 Transport



Material losses

If possible, transport the appliance to the installation location in its original packaging. If the appliance is transported without packaging and without using a pallet, e.g. to carry it up or down stairs, its outer casing may be damaged. To transport the appliance without packaging, first remove the front panel of the appliance. See chapter "Installation / Removing the front panel".



Material losses

Never use the air connections as handles for carrying the appliance.

10. Installation

10.1 Removing the front panel

Remove the front panel before removing the appliance from the pallet, to avoid damaging the appliance.

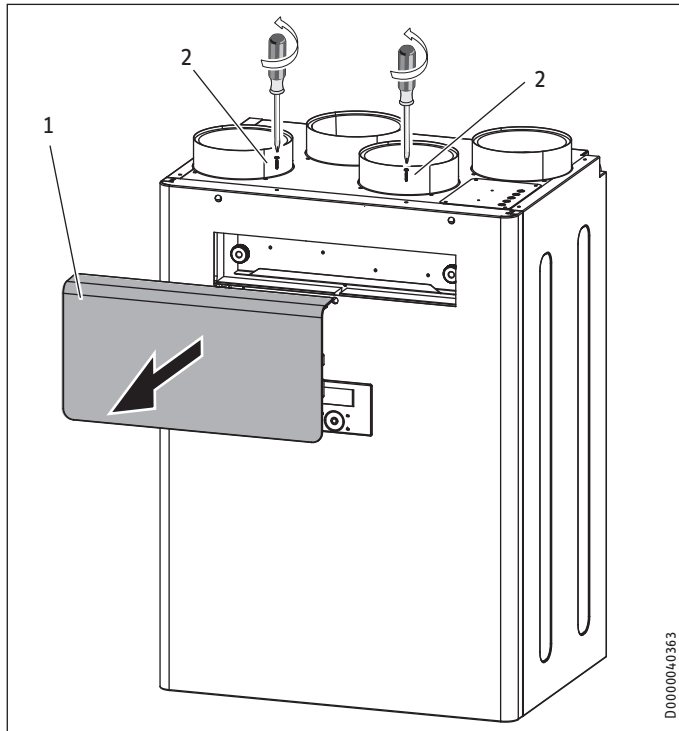

- 1 Fascia
- 2 Front panel fixing screws

The fascia is fastened to the appliance with locking tabs.

- ▶ To disengage the locking tabs, press the grip areas on the fascia sides.
- ▶ Remove the fascia from the appliance.
- ▶ Undo both screws securing the front panel at the top of the appliance.
- ▶ Carefully push the front panel upwards by a small amount to release it from the hooks on which it is engaged.

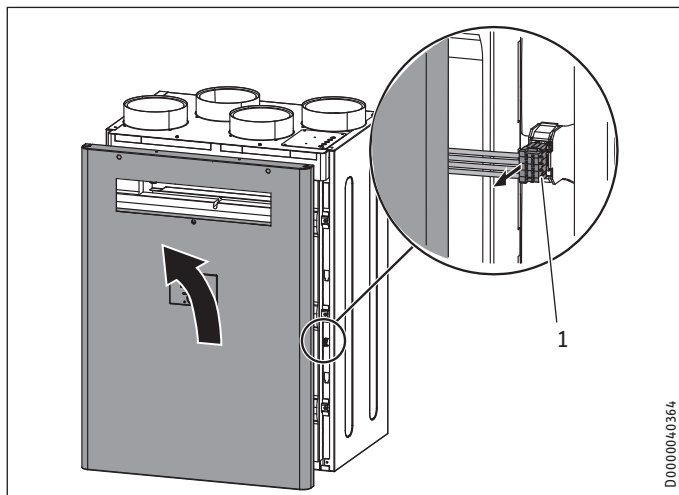

- 1 Plug on cable from programming unit to appliance

- ▶ Carefully raise the front panel by a small amount on the right-hand side.
- ▶ On the appliance, pull out the plug connecting the programming unit with the appliance.

10.2 Mounting the appliance



Material losses

- ▶ Check whether the wall can bear the weight of the appliance.
- ▶ Use appropriate rawl plugs and screws suitable for the wall structure to attach the rail.

- ▶ Remove the wall mounting bracket from the appliance.

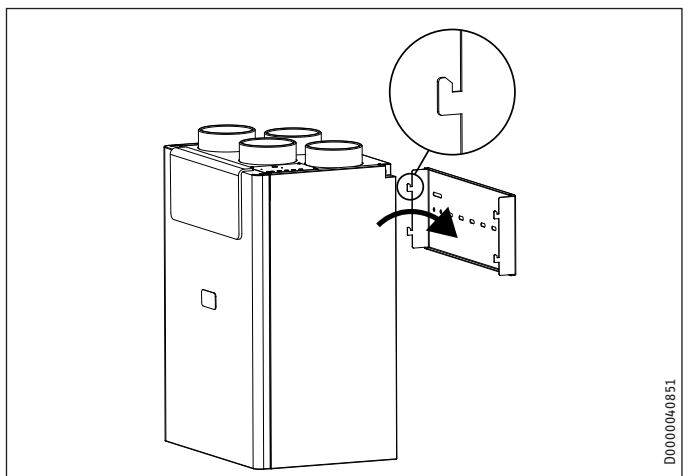

- ▶ Secure the wall mounting bracket to the wall with four screws. The text "TOP" must be at the top. The wall mounting bracket must be horizontal.
- ▶ If necessary, screw the star grips included in the standard delivery into the back of the appliance at the bottom to act as spacers.
- ▶ Fit the appliance onto the hooks of the wall mounting bracket.
- ▶ If the appliance is not hanging horizontally, screw the previously fitted star grips acting as spacers in or out by a small amount.

10.3 Connecting the condensate drain hose



Material losses

To ensure that condensate drains correctly, always lay the condensate drain hose without any kinks. Lay the condensate drain hose with a fall of at least 10 %. Ensure the appliance is level after installation. The drain pipe may only contain one siphon. The condensate must be able to drain freely downstream of the siphon. The condensate must drain away via the domestic sewer system. The pipes must not rise in the domestic sewer system downstream of the siphon. The condensate drain must be free from the risk of frost.

The standard delivery includes a condensate drain hose and a hose clip. Connect the thinner end of the condensate drain hose to the appliance.

INSTALLATION

Installation

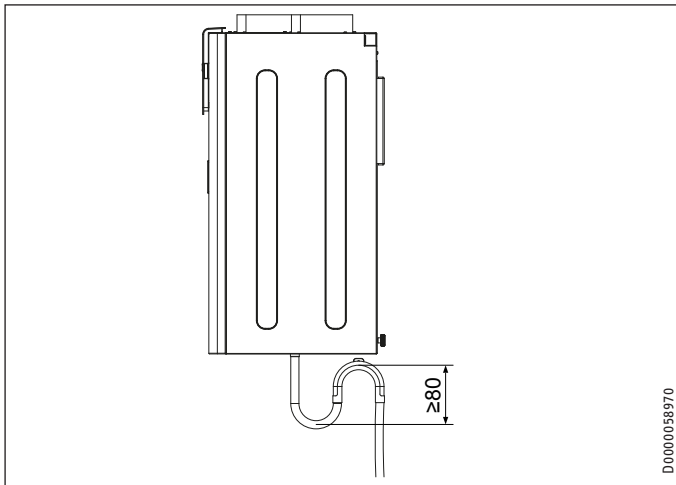

D0000058970

- ▶ Use the mounting bend included in the standard delivery to install the condensate drain hose in such a way as to create a siphon with a water trap height of at least 80 mm.
- ▶ Before connecting the condensate drain hose to the appliance, pour water into the siphon.

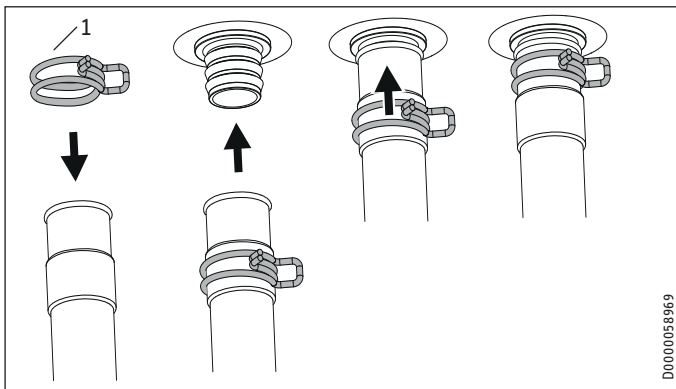

D0000058969

1 Hose clip

- ▶ Slide the hose clip onto the condensate drain hose far enough to be able to push the hose onto the condensate drain connector without squeezing the hose clip.
- ▶ Push the condensate drain hose onto the condensate drain connector.
- ▶ Push the hose clip towards the appliance so that it secures the hose on the condensate drain connector.

10.4 Air ducts

! Material losses
Never link cooker hoods to the ventilation system.

! Material losses
During installation, ensure that no metal swarf enters the pipework. However, should this occur, remove this debris, otherwise the fans may be damaged.

Install the air ducts using materials that can be obtained from us or with commercially available folded spiral-seam tubes.

10.4.1 Insulation against condensation

- ! Material losses**
When warm air meets cold surfaces, condensation can result.
- ▶ For outdoor air and exhaust air ducts, use vapour proof thermally insulated pipes.
 - ▶ If the supply and extract air ducts are routed through unheated rooms, insulate these ducts as well.

10.4.2 Connecting air ducts to the appliance

You can connect air ducts with two different diameters to the appliance.

Diameter DN 160

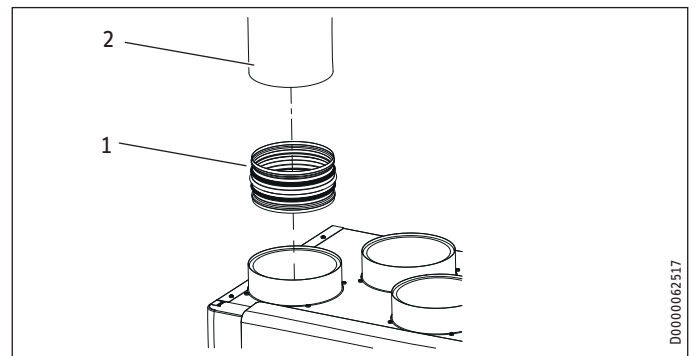

D0000062517

- 1 Twin connector
- 2 Air duct

- ▶ Push one of the twin connectors included in the standard delivery into the air connection.
- ▶ Push the air duct onto the twin connector.

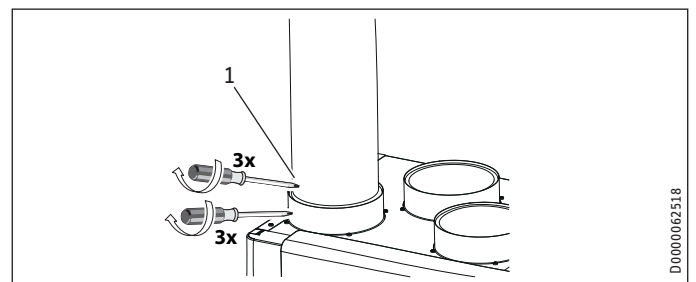

D0000062518

- 1 Self-tapping screw

- ▶ Use no more than 3 screws to secure the twin connector to the air connection of the appliance.
- ▶ Secure the air duct to the twin connector with no more than 3 screws.

Diameter DN 180

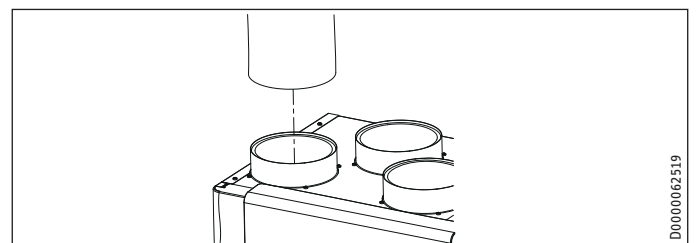

D0000062519

INSTALLATION

Installation

- ▶ Push the air duct over the air connector.

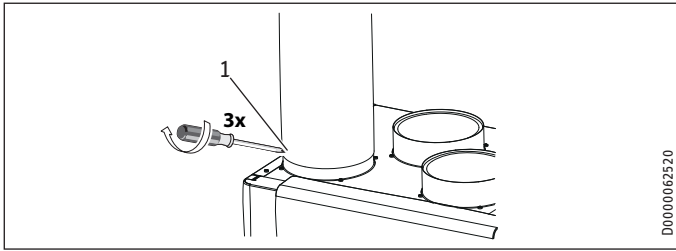

- 1 Self-tapping screw
- ▶ Use no more than 3 screws to secure the air duct to the air connection of the appliance.

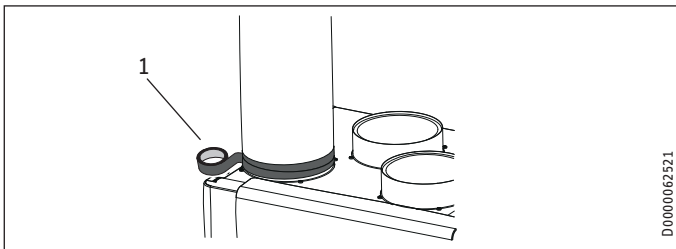

- 1 Aluminium sealing tape
- ▶ Seal the transition from the air connection to the air duct with aluminium sealing tape.

10.4.3 External wall ducts

Install the outdoor air intake into the building at a location where contamination (dust, soot, odours, flue gas, exhaust air) is as low as possible.

When installing external wall ducts, prevent any short circuit between the air intake and the air discharge.

10.4.4 Silencer

- ▶ Install a silencer in both the supply air duct and the extract air duct. Install these silencers as close as possible to the appliance, so that noise is suppressed at an early stage.

We recommend installing additional silencers if required to avoid sound transmission.

If a room with a high noise level needs to be ventilated, install additional silencers upstream of this room to reduce sound transmission to the neighbouring rooms.

Aspects such as carried voices and impact sound must also be taken into consideration in the case of ducts embedded in concrete. Carried voices should be avoided by designing the duct with separate branches to the vents. If necessary, insulate the supply air ducts, e.g. if they are mounted outside the insulated wall panel.

10.4.5 Overflow apertures

Living rooms and bedrooms are only supplied with air. Air is only extracted from rooms where odours and moisture are generated. Ensure an unimpeded overflow and consequently air balancing. Install ventilation grilles in internal doors or walls, or enlarge the air gap beneath the door to ≥ 8 mm.

10.4.6 Cleaning apertures

- ▶ Fit cleaning apertures when installing the air ducts, so that the air ducts can be inspected and cleaned at regular intervals.

10.4.7 Supply and extract air vents

Supply and extract air vents for the living space are available for wall or ceiling mounting.

When venting the kitchen, ensure that the extract air vent is fitted as far as possible from the cooker.

10.5 Fitting the front panel

- ▶ Push the plug on the cable leading to the programming unit into the appliance.
- ▶ Hook the front panel into the hooks provided at the front of the appliance.
- ▶ At the upper edge of the front panel, screw in the two screws for securing the front panel to the appliance.
- ▶ Fit the fascia.

10.6 Electrical connection



WARNING Electrocutation

Carry out all electrical connection and installation work in accordance with national and regional regulations.

Use the plug on the power cable to connect the appliance to a standard socket.

Take the power consumption of the preheating coil into consideration.

10.6.1 Safety equipment for stove/fireplace operation

- ▶ Install the safety equipment in such a way that it interrupts the appliance power supply when required.

10.6.2 Connections in the control panel (safety extra low voltage)

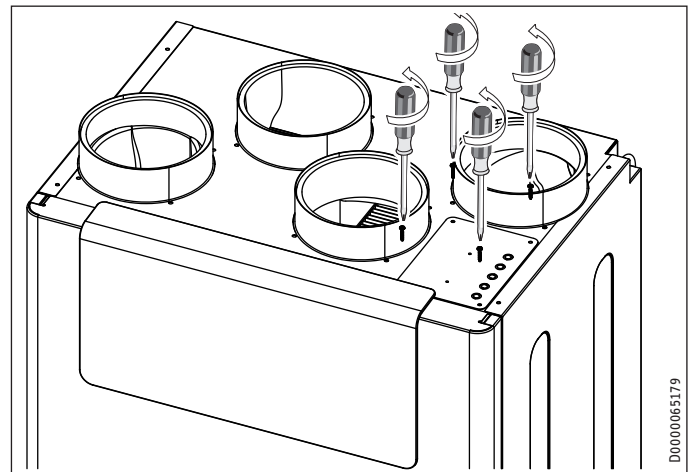

- ▶ Undo the four screws from the control panel cover.



Note

After completing your work, screw the cover back onto the control panel.

INSTALLATION

Commissioning

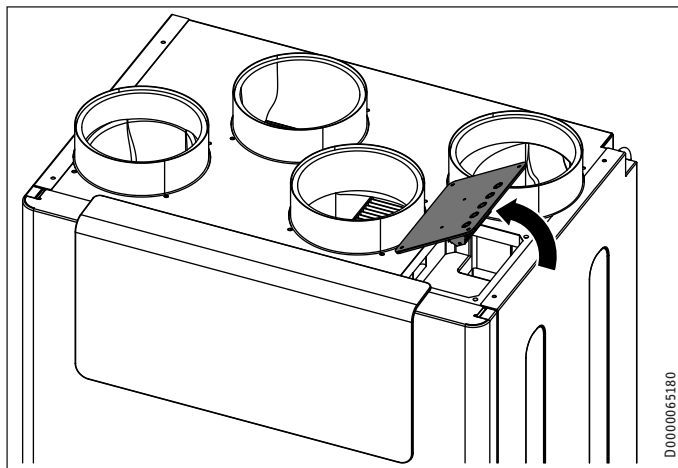

- Carefully lift up the control panel cover. The terminal block, from which cables lead into the appliance, is suspended from the underside of the cover.

| Terminal | | Safety extra low voltage |
|----------|---|-----------------------------------|
| 1 | I ² C bus | SCL External programming unit |
| 2 | | SCL |
| 3 | | GND External programming unit |
| 4 | | GND |
| 5 | | +5 V DC External programming unit |
| 6 | | +5 V DC |
| 7 | | SDA External programming unit |
| 8 | | SDA |
| 9 | Not assigned | Floating |
| 10 | | |
| 11 | | |
| 12 | | |
| 13 | Intensive ventilation switching contact | GND 0.5 mA max. |
| 14 | | +5 V |
| 15 | Not assigned | Floating |
| 16 | | |
| 17 | Not assigned | Floating |

To connect an electrical cable in the control panel:

- Open an "entry for electrical cables" at the knock-out.
- Use an M12 cable fitting to seal the "entry for electrical cables".

Intensive ventilation switching contact

You can connect a floating switching contact, the actuation of which switches the appliance to intensive ventilation. You can set the runtime for intensive ventilation in parameter P2. After this time has expired, the appliance returns to the previously applicable fan stage.

- Connect the external pushbutton to terminals 13/14.

External programming unit

The programming unit is connected with an I²C bus.

11. Commissioning



WARNING Injury
If the unit is switched on without the air ducts connected and someone reaches through the air connectors into the unit, there is a risk of injury.
Do not commission the unit until the air ducts are firmly connected to it.



Material losses
Never operate the appliance without filters.



Material losses
Never operate the ventilation system if there are high levels of dust inside the building or outside in the immediate vicinity, as this could block the filter. Dust is created by cutting tiles or working with plasterboard, for example.

11.1 Initial start-up

Enable fan

The fans are deactivated in the delivered condition.

- P28: Set the parameter to "On".

Setting air flow rates

- Use parameters P6 to P9 to set the air flow rates for the fan stages.

Date

- Set the current day of the week.

| | | |
|-----|---|-----------|
| P80 | 1 | Monday |
| | 2 | Tuesday |
| | 3 | Wednesday |
| | 4 | Thursday |
| | 5 | Friday |
| | 6 | Saturday |
| | 7 | Sunday |

Time

- Set the current time.

P81 00:00 - 23:59

11.2 Recommissioning

- Check whether filters are fitted in the appliance. Never operate the appliance without filters.
- Check whether the condensate drain hose is damaged or kinked.

12. Settings

When you enter a four-digit code, additional actual values become visible, which were hidden beforehand.

12.1 Parameter



Note

P6, P7, P8, P9: This parameter is displayed only if P5 = 0.

P10, P11, P12, P13: This parameter is displayed only if P5 = 1.

P28: Delivered condition OFF

| | Description | Code | Unit | LWZ 180, LWZ 180 Enthalpie | | | LWZ 280, LWZ 280 Enthalpie | | | | |
|-----|--|------|-------|----------------------------|-------|--|----------------------------|-------|-------|--|---------------|
| | | | | Min. | Max. | Options | Stand- ard | Min. | Max. | Options | Stand- ard |
| P1 | Set room temperature | A0 | °C | 5 | 28 | | 20 | 5 | 28 | | 20 |
| P2 | Intensive ventilation runtime | A0 | Min. | 1 | 240 | | 30 | 1 | 240 | | 30 |
| P3 | Bypass mode | A0 | | | | 0 1 2 3 | 2 | | | 0 1 2 3 | 2 |
| P4 | Reset filter | A0 | | | | 0 1 | - | | | 0 1 | - |
| P5 | Fan operating mode | A1 | | | | 0 1 | 0 | | | 0 1 | 0 |
| P6 | Flow rate, stage 0 | A1 | m³/h | 40 | 120 | | 60 | 40 | 150 | | 60 |
| P7 | Flow rate, stage 1 | A1 | m³/h | 80 | 265 | | 130 | 80 | 335 | | 165 |
| P8 | Flow rate, stage 2 | A1 | m³/h | 130 | 350 | | 180 | 130 | 400 | | 280 |
| P9 | Flow rate, stage 3 | A1 | m³/h | 165 | 400 | | 235 | 165 | 400 | | 350 |
| P10 | Constant pressure, stage 0 | A1 | Pa | 40 | 160 | | 40 | 40 | 160 | | 40 |
| P11 | Constant pressure, stage 1 | A1 | Pa | 40 | 160 | | 50 | 40 | 160 | | 50 |
| P12 | Constant pressure, stage 2 | A1 | Pa | 40 | 160 | | 70 | 40 | 160 | | 70 |
| P13 | Constant pressure, stage 3 | A1 | Pa | 40 | 160 | | 100 | 40 | 160 | | 100 |
| P14 | Supply air flow rate offset | A1 | | -100 | 100 | | 0 | -100 | 100 | | 0 |
| P15 | Humidity protection interval | A1 | h | 1 | 24 | | 1 | 1 | 24 | | 1 |
| P16 | Start-up time for humidity measurement | A1 | min | 1 | 15 | | 5 | 1 | 15 | | 5 |
| P17 | Extract air humidity limit | A1 | % | 5 | 95 | | 65 | 5 | 95 | | 65 |
| P18 | Frost protection temperature | A1 | °C | -5.0 | 15.0 | | 4.0 | -5.0 | 15.0 | | 4.0 |
| P19 | Filter change interval | A1 | d | 1 | 365 | | 90 | 1 | 365 | | 90 |
| P22 | Enable preheater | A1 | | | | 0 1 | 1 | | | 0 1 | 1 |
| P23 | Frost protection mode | A1 | | | | 0 2 | 2 | | | 0 2 | 2 |
| P24 | Bypass enable temperature | A1 | °C | 5.0 | 15.0 | | 10.0 | 5.0 | 15.0 | | 10.0 |
| P25 | Bypass blocking temperature | A1 | °C | 5.0 | 15.0 | | 8.0 | 5.0 | 15.0 | | 8.0 |
| P26 | Bypass hysteresis | A1 | K | 0.0 | 5.0 | | 2.0 | 0.0 | 5.0 | | 2.0 |
| P27 | Temperature differential for enabling the bypass | A1 | °C | 0.0 | 5.0 | | 2.0 | 0.0 | 5.0 | | 2.0 |
| P28 | Enable fan | A0 | | | | On OFF | On | | | On OFF | On |
| P29 | Appliance type | A1 | | | | | 1 | | | | 2 |
| P30 | Temperature for enabling frost protection | A2 | °C | -5.0 | 5.0 | | -3.0 | -5.0 | 5.0 | | -3.0 |
| P31 | Enabling of humidity-dependent flow rate control | A1 | | | | 0 1 | 0 | | | 0 1 | 0 |
| P70 | Delete fault list | A1 | | | | 0 1 | - | | | 0 1 | - |
| P80 | Day | A0 | | 1 | 7 | | | 1 | 7 | | |
| P81 | Time | A0 | | 00:00 | 23:59 | | | 00:00 | 23:59 | | |
| P82 | Level of lighting | A0 | Level | 2 | 10 | | 10 | 2 | 10 | | 10 |
| P83 | Mode of backlighting | A0 | | | | Auto On OFF | Auto | | | Auto On OFF | Auto |
| P84 | Illumination duration | A0 | s | 10 | 500 | | 60 | 10 | 500 | | 60 |
| P85 | Lower standard display | A0 | | | | OFF Time Set room temperature Extract air temperature Extract air humidity | | | | OFF Time Set room temperature Extract air temperature Extract air humidity | |

■ P5: Fan operating mode

Use this parameter to switch between flow rate control and constant pressure control.

| Effect | |
|--------|---|
| 0 | The appliance maintains a constant flow rate for both fans. The appliance operates with set flow rates P6 to P9. |
| 1 | The appliance maintains a constant pressure at the extract air fan. The appliance regulates the pressure at the extract air connector to the set values saved in P10 to P13. The flow rate that is established there is used as the set value for flow rate control of the supply air fan. The supply air flow rate offset set in parameter P14 is also taken into account. |

■ P14: Supply air flow rate offset

Use this parameter to adjust the supply air flow rate during commissioning. The offset refers to standard ventilation and is converted internally as a percentage for the other fan stages.

Example

- Nominal flow rate (stage 2): 180 m³/h
- Offset: 45 m³/h

| Stage | Set flow rate | Off-set | Set flow rate + Offset | Offset factor | Internal set flow rate = Set flow rate * Offset factor |
|-------|---------------|---------|------------------------|----------------|--|
| 0 | 50 | | | | 50*1.25 = 62 |
| 1 | 130 | | | | 130*1.25 = 162 |
| 2 | 180 | 45 | 180+45 = 225 | 225/180 = 1.25 | 180*1.25 = 225 |
| 3 | 235 | | | | 235*1.25 = 294 |

■ P15: Humidity protection interval

If you set fan stage 0, the appliance switches to a 24 hour dormant phase. The humidity protection control unit only starts after this.

The appliance measures the humidity of the extract air for the time set in P16. The appliance compares the last measured value with the limit value set in P17. If the limit value is exceeded, the appliance starts to ventilate. If the limit is undershot again, the appliance terminates ventilation. At this point, the humidity protection interval restarts, at the end of which the moisture is measured.

■ P16: Start-up time for humidity measurement

The appliance measures the humidity of the extract air for the time set in P16. The appliance compares the last measured value with the limit value set in P17.

■ P22: Enable preheater

| Effect | |
|--------|--|
| 0 | The internal preheater is completely deactivated. |
| 1 | The internal preheater is activated. In order to keep the heat exchanger free from ice, the preheater ensures a minimum supply air temperature with reference to the frost protection temperature adjustable in parameter P18. |

While this parameter is being displayed or adjusted, the "frost protection" symbol is shown on the display.

■ P23: Frost protection mode

| Effect | |
|--------|--|
| 0 | At this setting, the appliance operates solely in frost protection mode. The preheating coil control only measures the outside temperature. |
| 2 | At this setting, the appliance operates in comfort mode. In addition to the outside temperature, the supply air temperature is also measured. The preheating coil is controlled to ensure that the supply air temperature does not fall below the 16.5 °C specified in the passive house criteria. |

■ P24: Bypass enable temperature

To enable checking of the other parameters for the bypass, the outdoor air temperature must be no less than the value set in this parameter.

■ P25: Bypass blocking temperature

If the outdoor air temperature falls below this blocking temperature, the bypass is deactivated.

■ P26: Bypass hysteresis

To make cooling possible, the outdoor air temperature must be lower than the extract air temperature by the value set in this parameter.

■ P27: Temperature differential for enabling the bypass

Use this parameter to define the temperature differential that must be exceeded for the bypass to be enabled. In order for the bypass to be enabled, the following must apply.

$$P3 = 2: \text{Outdoor air temperature} > \text{Set room temperature} + P27$$

$$P3 = 3: \text{Extract air temp.} > \text{Set room temperature} + P27$$

■ P29: Appliance type

This parameter is set at the factory. The parameter can only be set after the controller assembly has been replaced.

■ P30: Temperature for enabling frost protection

The unit only activates frost protection heating if the outdoor air temperature drops to the value that can be set in this parameter.

■ P31: Enabling of humidity-dependent flow rate control

With humidity-dependent flow rate control, the air flow rate is increased or decreased depending on the humidity level.

| Effect | |
|--------|----------|
| 0 | Disabled |
| 1 | enabled |

■ P70: Delete fault list

To delete the fault list, set this parameter to 1. Press the "OK" button to confirm. Afterwards, 0 is displayed again and the fault list is deleted.

12.2 Actual values

| Display | Description | Unit |
|---------|--|-------------------|
| l1 | Bypass damper status | |
| l2 | Extract air temperature | °C |
| l3 | Relative humidity of extract air | % |
| l4 | Filter service life | h |
| l5 | Appliance software version | |
| l6 | Unit software patch | |
| l7 | Terminal device serial number | |
| l8 | Programming unit software version | |
| l9 | Outdoor air temperature | °C |
| l10 | Supply air temperature | °C |
| l11 | Exhaust air temperature | °C |
| l12 | Relative humidity of outdoor air | % |
| l13 | Extract air dew point | °C |
| l14 | Outdoor air dew point | °C |
| l15 | Supply air fan drive output | % |
| l16 | Calculated supply air flow rate | m ³ /h |
| l17 | Exhaust air fan drive output | % |
| l18 | Calculated exhaust air flow rate | m ³ /h |
| l19 | Percentage output of internal preheating | % |
| l20 | Ventilation unit operating time | d |
| l21 | Fan operating time | d |
| l22 | Extract air pressure differential | Pa |
| l23 | Fan speed, supply air fan | rpm |
| l24 | Fan speed, exhaust air fan | rpm |
| l70-79 | Fault | |

12.3 Code

■ Cod

Enter 1000 to enable actual values and parameters which are reserved for qualified contractors. "A1" is shown on the display when this is entered correctly.

13. Appliance shutdown

We recommend running the appliance in fan stage 1, even during prolonged absence.



Material losses

If you interrupt the power supply to the appliance, check that humidity protection is ensured for the building.

If the appliance needs to be taken out of use for an extended period, disconnect it from the power supply by pulling the mains plug.

- ▶ Replace the filters.

14. Maintenance



WARNING Electrocutation

Disconnect the appliance from the power supply before carrying out work inside the appliance.

- ▶ Pull the mains plug out of the socket.

Maintenance by the qualified contractor includes cleaning the cross-countercurrent heat exchanger and the fans. Subject to runtime, this maintenance work should be carried out every 3 years.

- ▶ Disconnect the power supply by pulling the power plug from its socket.
- ▶ Remove the front panel (see chapter "Installation / Removing the front panel").
- ▶ Remove the filter drawer from the appliance.

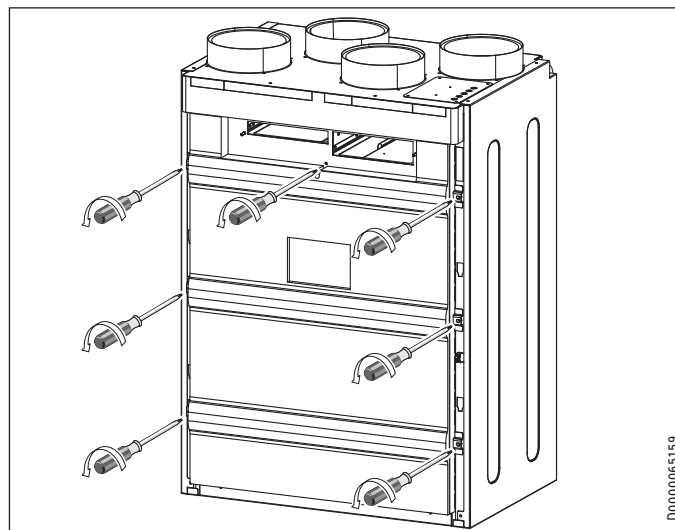

- ▶ Undo the screws on the inner front panel.
- ▶ Remove the inner front panel from the appliance by tilting the inner front panel forwards and then lifting it out of the bottom slots.

INSTALLATION

Maintenance

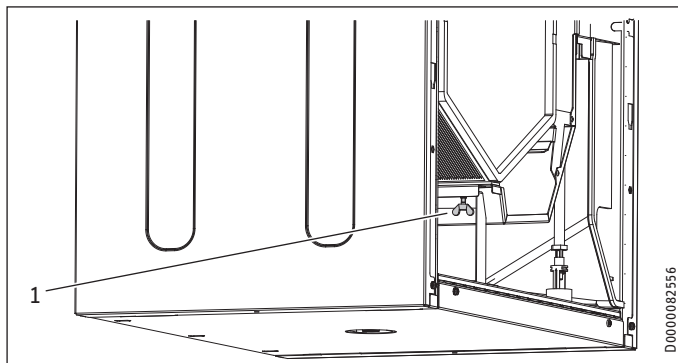

1 Wing screw

- ▶ To remove the heat exchanger from the appliance, undo the wing screw, which pushes the support bar against the heat exchanger from below.

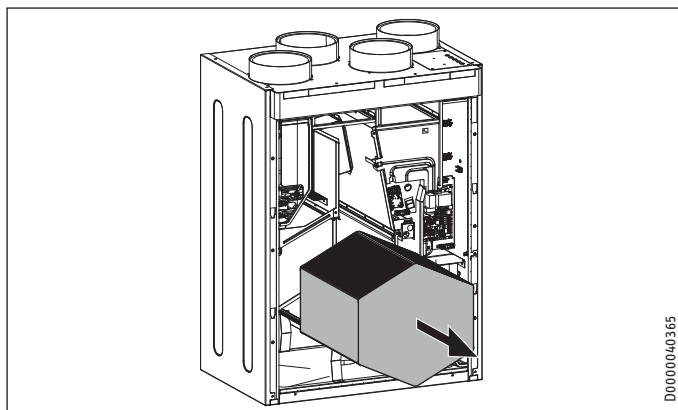

- ▶ Carefully remove the heat exchanger from the unit. Avoid damaging the gaskets in the appliance.
- ▶ Use a commercially available vacuum cleaner to remove dust and other loose dirt particles from the intake and discharge surfaces.

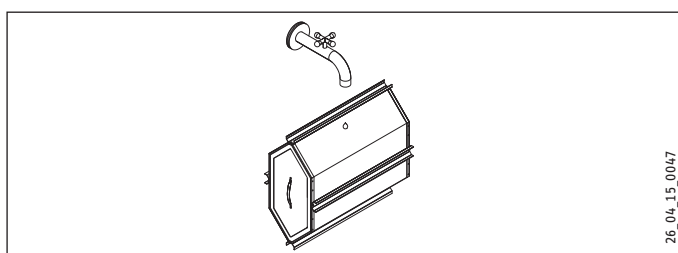

- ▶ If required, clean the heat exchanger with warm water (max. 55 °C) and a commercially available detergent. Do not use solvents.
- ▶ Flush the heat exchanger with water.

Cleaning the fan units

Each fan unit has a rotating eccentric bolt at the bottom. To ensure that the seals fit correctly on the fan unit, the eccentric bolt raises the fan unit while pushing it towards the back. Release the eccentric bolt before pulling out the fan unit. Retighten the eccentric bolt after installing the fan unit.

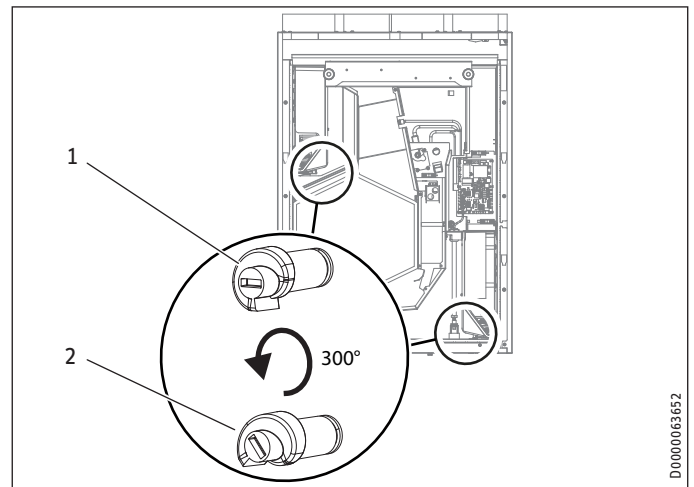

- 1 Eccentric bolt tightened (slot horizontal)
- 2 Eccentric bolt released

- ▶ Use a medium sized screwdriver to turn the eccentric bolt anti-clockwise by 300°.
- ▶ Carefully pull both fan units from the appliance by a small amount.

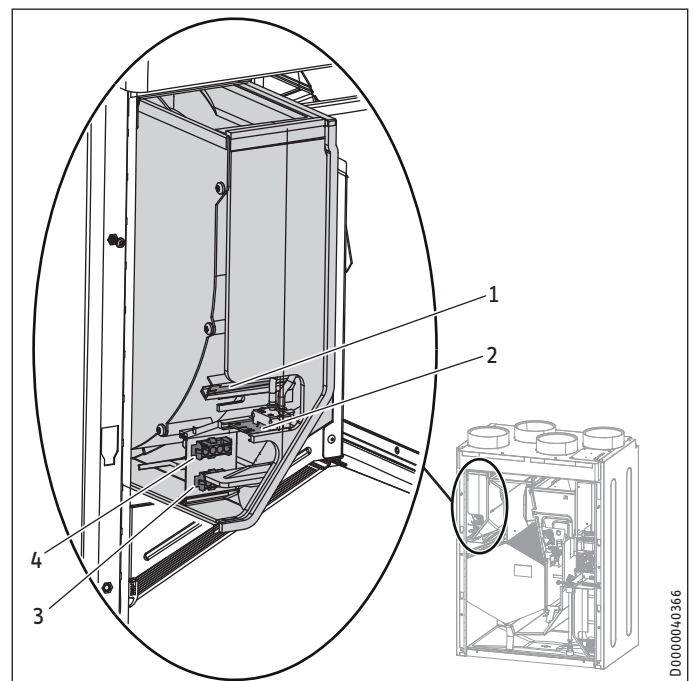

- 1 Temperature sensor connection
- 2 Pressure sensor connection
- 3 Connection for the fan power cable
- 4 Connection for the fan control cable

- ▶ At the front of the supply air fan, disconnect the 3-core power cable and the 4-core control cable.
- ▶ Disconnect the 6-core common cable for the pressure sensor and temperature sensor. Four cores of the cable are connected to the pressure sensor connection. Two cores of the cable are connected to the temperature sensor connection.
- ▶ Remove the supply air fan from the appliance.

INSTALLATION

Troubleshooting

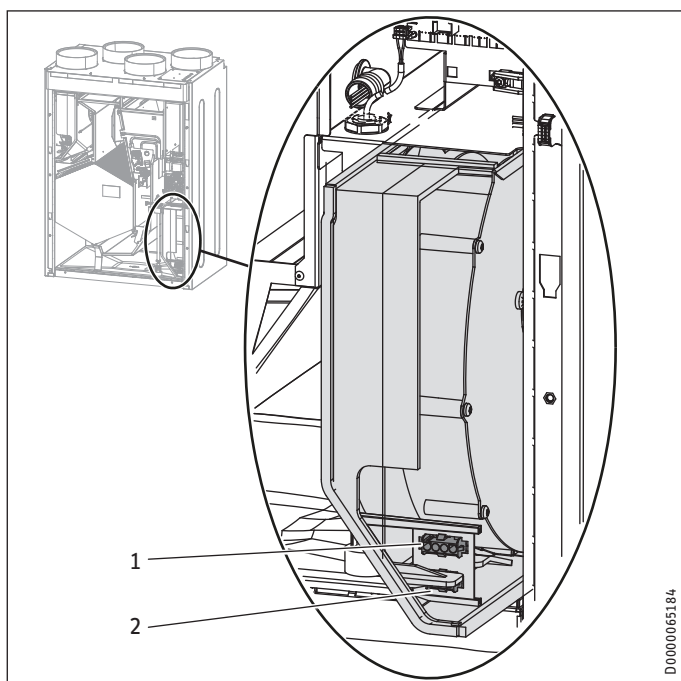

- 1 Connection for the fan control cable
- 2 Connection for the fan power cable

- ▶ At the front of the exhaust air fan, disconnect the 3-core power cable and the 4-core control cable.
- ▶ At the back of the exhaust air fan, disconnect the 6-core common cable for the pressure sensor and temperature sensor. Four cores of the cable are connected to the pressure sensor connection. Two cores of the cable are connected to the temperature sensor connection.
- ▶ Remove the exhaust air fan from the appliance.
- ▶ Clean the fans with a soft brush.

Refitting the components

- ▶ Push the fan units back into the appliance.
- ▶ Turn the eccentric bolts under the fan units clockwise by 300°. The slot at the front of the eccentric bolts must be horizontal.
- ▶ Reconnect the fan cables.
- ▶ Slide the heat exchanger back into the appliance.
- ▶ To ensure that the support bar pushes the partition under the heat exchanger, tighten the wing screw until finger-tight. The top three gaskets must be in contact with the heat exchanger and become slightly deformed.
- ▶ Fit the inner front panel which ensures the appliance is air-tight. Secure the inner front panel with seven screws.
- ▶ Hook the front panel into the hooks provided at the front of the appliance.
- ▶ Secure the front panel with the screws at the top.
- ▶ Push the filter drawer into the appliance. The clean side of the filters must face down.
- ▶ Hook the fascia into the appliance.

Checking the condensate drain



Note

The appliance will only function correctly if the condensate drain is working and is filled.

- ▶ Check the condensate drain at regular intervals – at least once every six months.

Cleaning the air ducts

Air ducts must be checked at regular intervals and cleaned if necessary. Disconnect the air ducts from the appliance or carry out inspection and cleaning through the extract air and supply air vents.

15. Troubleshooting



WARNING Electrocutation

Disconnect the power supply by unplugging the appliance from the mains before carrying out work inside the appliance.



WARNING Electrocutation

The power cable must only be replaced (for example if damaged) by a qualified contractor authorised by the manufacturer, using an original spare part.

Fault (Exxx)

| xxx | Fault | Effect | Remedy |
|-----|---|---|--|
| --- | No fault present | | |
| 1 | Short circuit Supply air temperature sensor | No control to the comfort temperature required for passive houses of at least 16.5 °C in the supply air | Isolate the appliance from the power supply. Check the sensor cable. Unplug connector X7 from the electronic assembly. Test the sensor. |
| 2 | Lead break Supply air temperature sensor | No control to the comfort temperature required for passive houses of at least 16.5 °C in the supply air | Isolate the appliance from the power supply. Check the sensor cable. Unplug connector X7 from the electronic assembly. Test the sensor. |
| 3 | Short circuit Exhaust air temperature sensor | No effect | Isolate the appliance from the power supply. Check the sensor cable. Unplug connector X8 from the electronic assembly. Test the sensor. |
| 4 | Lead break Exhaust air temperature sensor | No effect | Isolate the appliance from the power supply. Check the sensor cable. Unplug connector X8 from the electronic assembly. Test the sensor. |
| 5 | No differential pressure Supply air | The appliance controls the fan with the maximum value of the currently set fan stage. | Isolate the appliance from the power supply. Check the sensor cable. Check the pressure hoses for contamination and damage. If necessary, replace the sensor and the hose. |
| 6 | No differential pressure Exhaust air | The appliance controls the fan with the maximum value of the currently set fan stage. | Isolate the appliance from the power supply. Check the sensor cable. Check the pressure hoses for contamination and damage. If necessary, replace the sensor and the hose. |

| xxx | Fault | Effect | Remedy |
|-----|--|--|---|
| 7 | No differential pressure sensor Extract air | Constant pressure control is not possible. The appliance switches to flow rate control. | Isolate the appliance from the power supply. Check the sensor cable. Check the pressure hoses for contamination and damage. If necessary, replace the sensor and the hose. Check the setting of the fan operating mode in menu item P5. |
| 8 | No humidity value for the extract air | The unit cannot provide humidity protection. | Isolate the appliance from the power supply. Check the sensor cable. Replace the sensor. |
| 9 | No humidity value for the outdoor air | The unit cannot provide humidity protection. | Isolate the appliance from the power supply. Check the sensor cable. Replace the sensor. |
| 10 | No temperature value for the extract air | Automatic bypass mode is not possible. Manual changeover of the bypass damper with options 0 and 1 of parameter P3 is possible. | Isolate the appliance from the power supply. Check the sensor cable. |
| 11 | No temperature value for the outdoor air | Automatic bypass mode is not possible. Manual changeover of the bypass damper with options 0 and 1 of parameter P3 is possible. | Isolate the appliance from the power supply. Check the sensor cable. |
| 16 | The condensate float switch has responded. | The unit switches off the fans. | Check the condensate drain. Check the cable for breakages. |
| 101 | Supply air fan | The unit does not receive any speed feedback from the fan. There is no effect on the flow rate control mode. | Isolate the appliance from the power supply. Check the cabling. Check the PWM control signal that the electronic assembly sends to the fan. Check the speed signal that the fan sends to the electronic assembly. Replace the fan. |
| 102 | Exhaust air fan | The unit does not receive any speed feedback from the fan. There is no effect on the flow rate control mode. | Isolate the appliance from the power supply. Check the cabling. Check the PWM control signal that the electronic assembly sends to the fan. Check the speed signal that the fan sends to the electronic assembly. Replace the fan. |
| 201 | No RTC communication (RTC = real-time clock) | Time-dependent program sequences are disrupted. | Isolate the appliance from the power supply. Replace the electronic assembly. |
| 202 | No RTC pulse | Time-dependent program sequences are disrupted. | Isolate the appliance from the power supply. Replace the electronic assembly. |
| 203 | Sensor voltage too low | The unit controls the fans with the maximum value of the currently set fan stage. The unit cannot provide humidity protection. Automatic bypass mode is not possible. Manual changeover of the bypass damper with options 0 and 1 of parameter P3 is possible. | Isolate the appliance from the power supply. Check the sensor voltage after disconnecting one of the following sensor plugs: X15, X16, X23, X24. Replace the sensor. Replace the electronic assembly. |
| 204 | Supply air shutdown | If the supply air temperature falls below 5 °C, the fan is switched off. | Check the preheating coil. |

Sensor resistance values



Note

When measuring with a multimeter, the resistance values serve only to identify faulty or incorrect sensors. Measuring with a multimeter is too imprecise to test for accuracy.

| | Sensor type |
|-------------|-------------|
| Supply air | PT 1000 |
| Exhaust air | PT 1000 |

| Temperature [°C] | PT 1000 Resistance [Ω] |
|------------------|------------------------|
| -30 | 882 |
| -20 | 922 |
| -10 | 961 |
| 0 | 1000 |
| 10 | 1039 |
| 20 | 1078 |
| 25 | 1097 |
| 30 | 1117 |
| 40 | 1155 |
| 50 | 1194 |
| 60 | 1232 |
| 70 | 1271 |
| 80 | 1309 |
| 90 | 1347 |
| 100 | 1385 |
| 110 | 1423 |
| 120 | 1461 |

16. Disposal

Removal



WARNING Electrocutation

Disconnect the appliance from the power supply.

The following tools are required for disassembly and material separation prior to disposal:

- Personal protective equipment
- Set of screwdrivers
- Set of spanners
- Combi pliers
- Stanley knife

17. Specification

17.1 Dimensions and connections

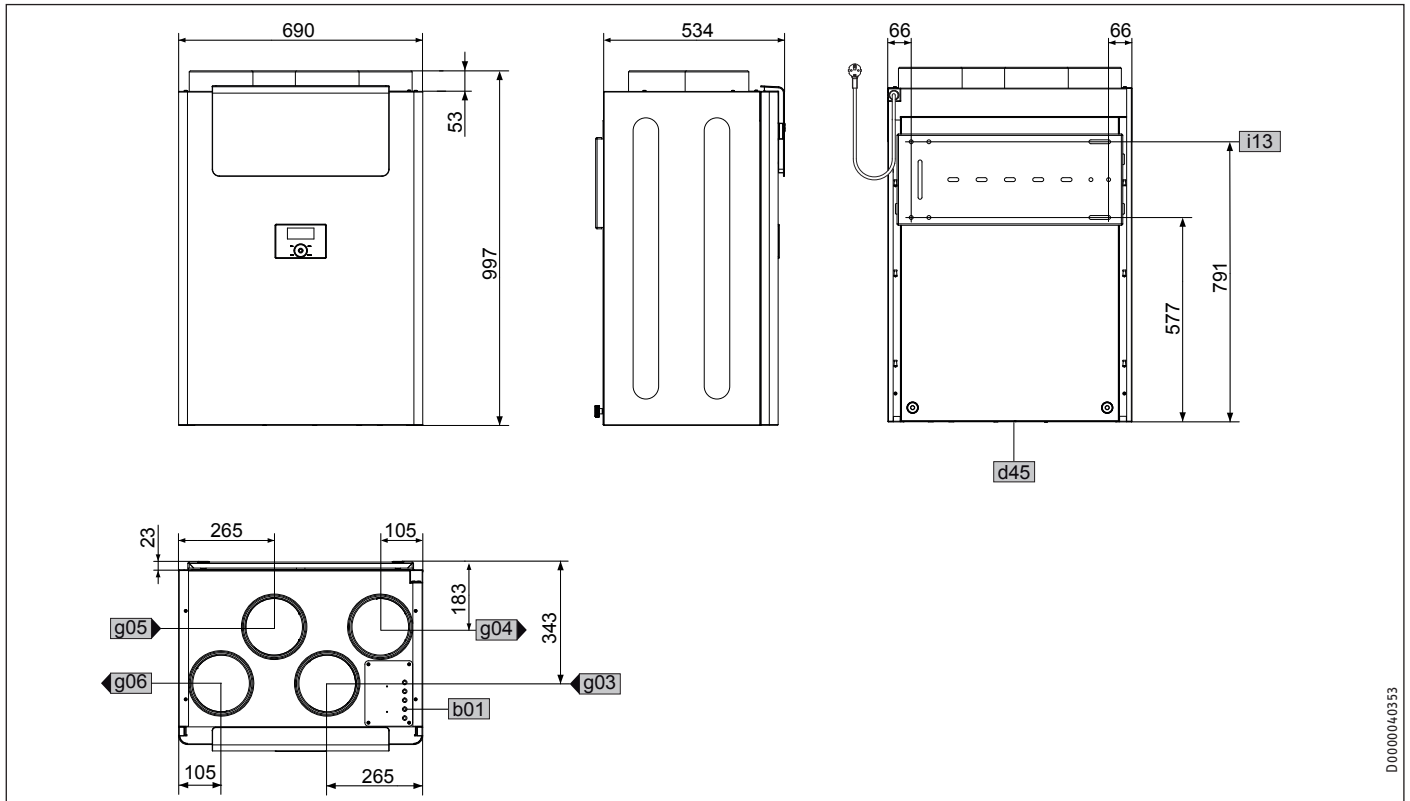

D0000040353

| | | | LWZ 180 | LWZ 280 | LWZ 180 Enthalpie | LWZ 280 Enthalpie |
|-----|-------------------------|----------|---------|-----------|-------------------|-------------------|
| b01 | Entry electrical cables | | | | | |
| d45 | Condensate drain | Diameter | mm | 22 | 22 | 22 |
| g03 | Outdoor air | Diameter | mm | 160 / 180 | 160 / 180 | 160 / 180 |
| g04 | Exhaust air | Diameter | mm | 160 / 180 | 160 / 180 | 160 / 180 |
| g05 | Extract air | Diameter | mm | 160 / 180 | 160 / 180 | 160 / 180 |
| g06 | Supply air | Diameter | mm | 160 / 180 | 160 / 180 | 160 / 180 |
| i13 | Wall mounting bracket | | | | | |

17.2 Wiring diagram

| | | | |
|-----|--|-----|---|
| X1 | Power supply | X19 | Switching contact on terminal block |
| X2 | Heating coils | X20 | Intensive ventilation switching contact |
| X3 | Supply air fan power cable | X21 | Exhaust air fan control cable |
| X4 | Exhaust air fan power cable | X22 | Supply air fan control cable |
| X6 | Float switch | X23 | Exhaust air pressure sensor |
| X7 | Supply air temperature sensor | X24 | Supply air pressure sensor |
| X8 | Exhaust air temperature sensor | ZUL | Supply air |
| X11 | I ² C bus at terminal block | FOL | Exhaust air |
| X12 | Internal programming unit | AUL | Outdoor air |
| X13 | External programming unit | ABL | Extract air |
| X15 | Outdoor air humidity sensor | | |
| X16 | Extract air humidity sensor | | |
| X17 | Bypass damper motor | | |

INSTALLATION Specification

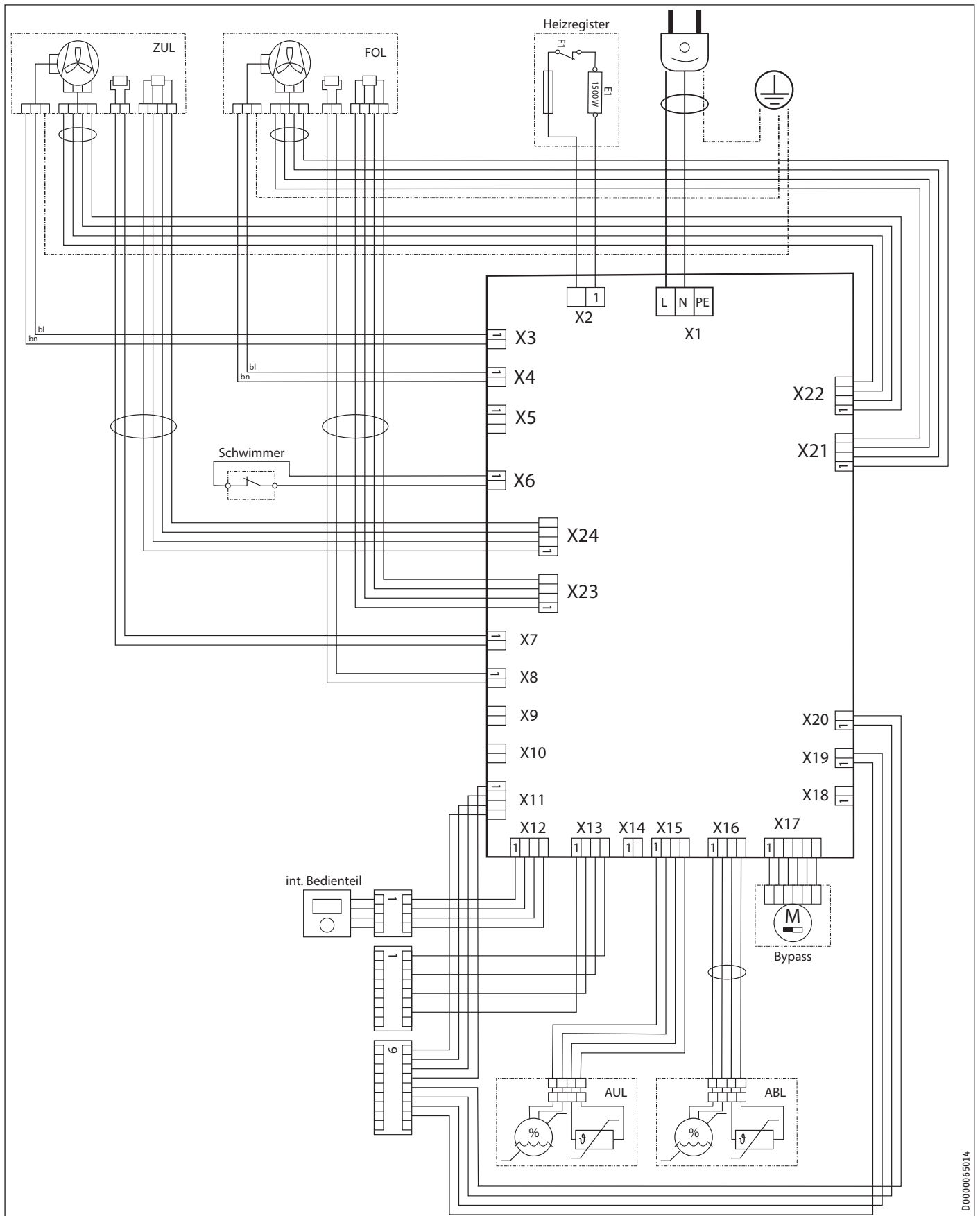

ENGLISH

D0000065014

INSTALLATION Specification

17.3 Fan diagram

The graph shows the pressure drop for examples of air distribution systems.

LWZ 180 / LWZ 180 Enthalpie

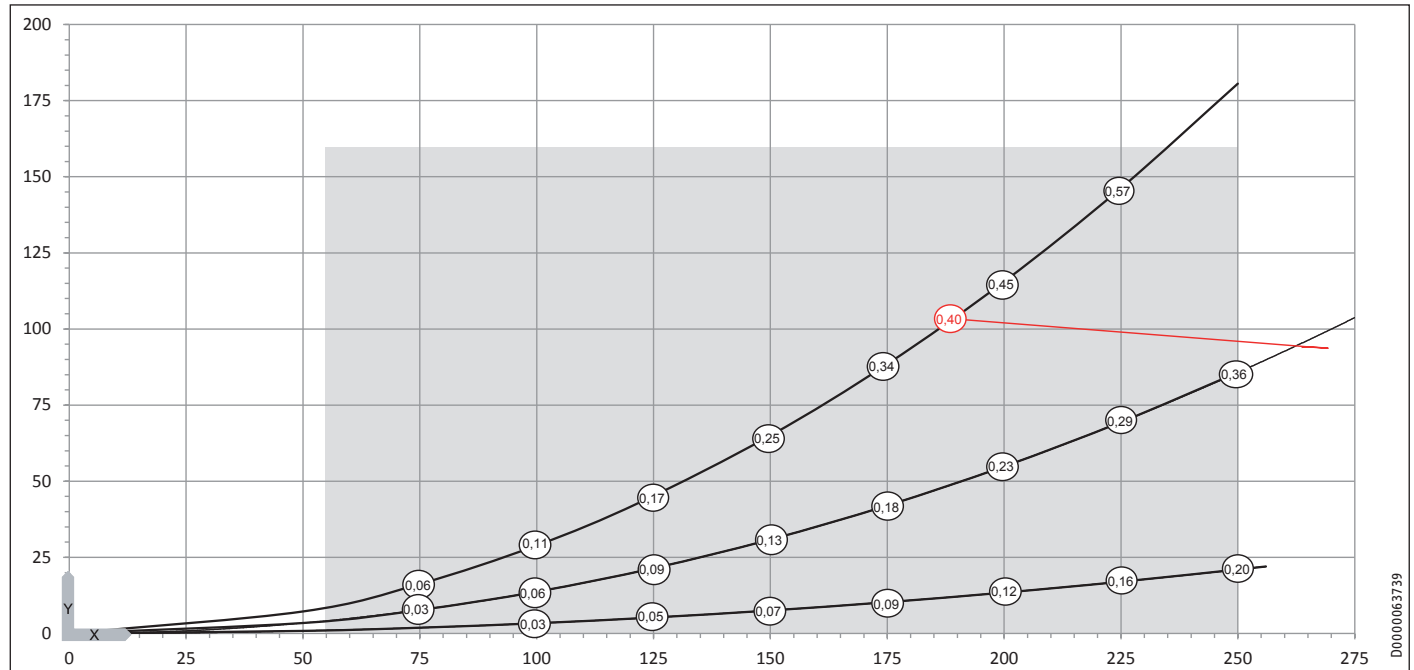

- X Air flow rate [m³/h]
- Y Average value, static pressure [Pa]
- ⊙ Power consumption of both fans [Wh/m³]
- Application range

LWZ 280 / LWZ 280 Enthalpie

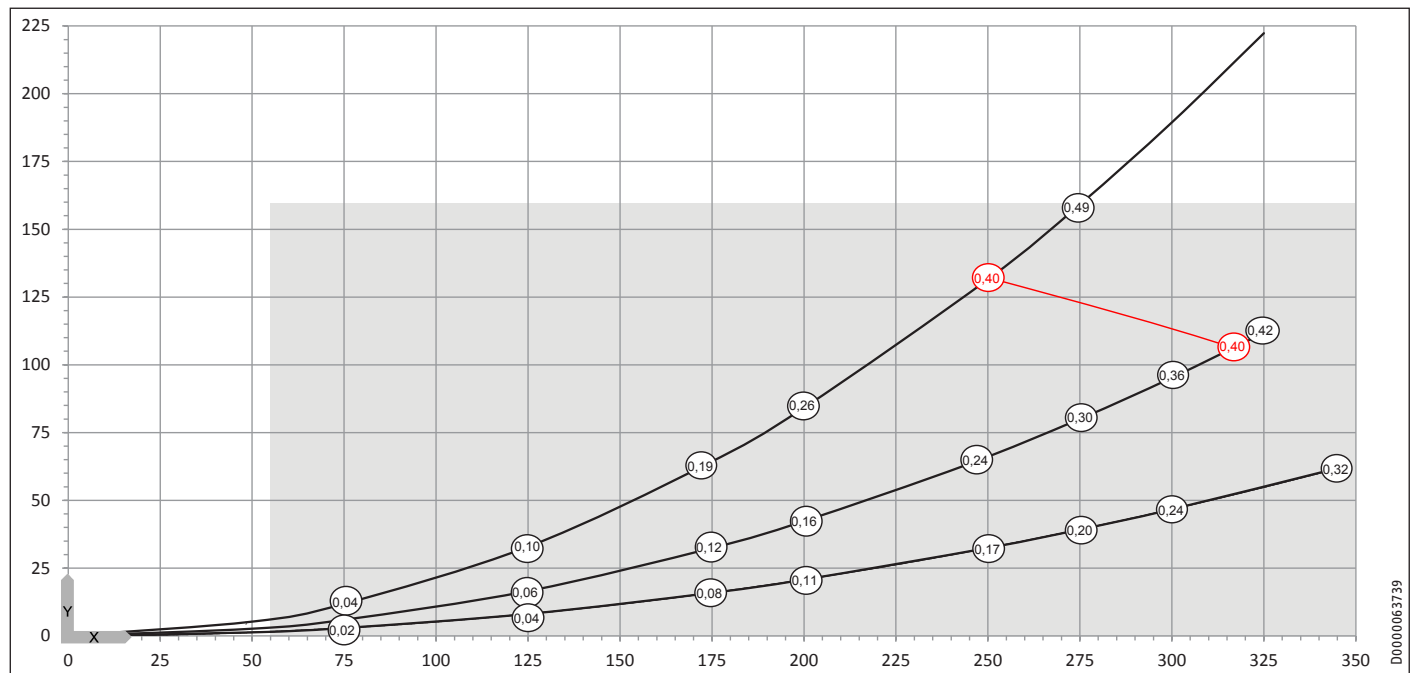

- X Air flow rate [m³/h]
- Y Average value, static pressure [Pa]
- ⊙ Power consumption of both fans [Wh/m³]
- Application range